

# Cold Rolling Mills

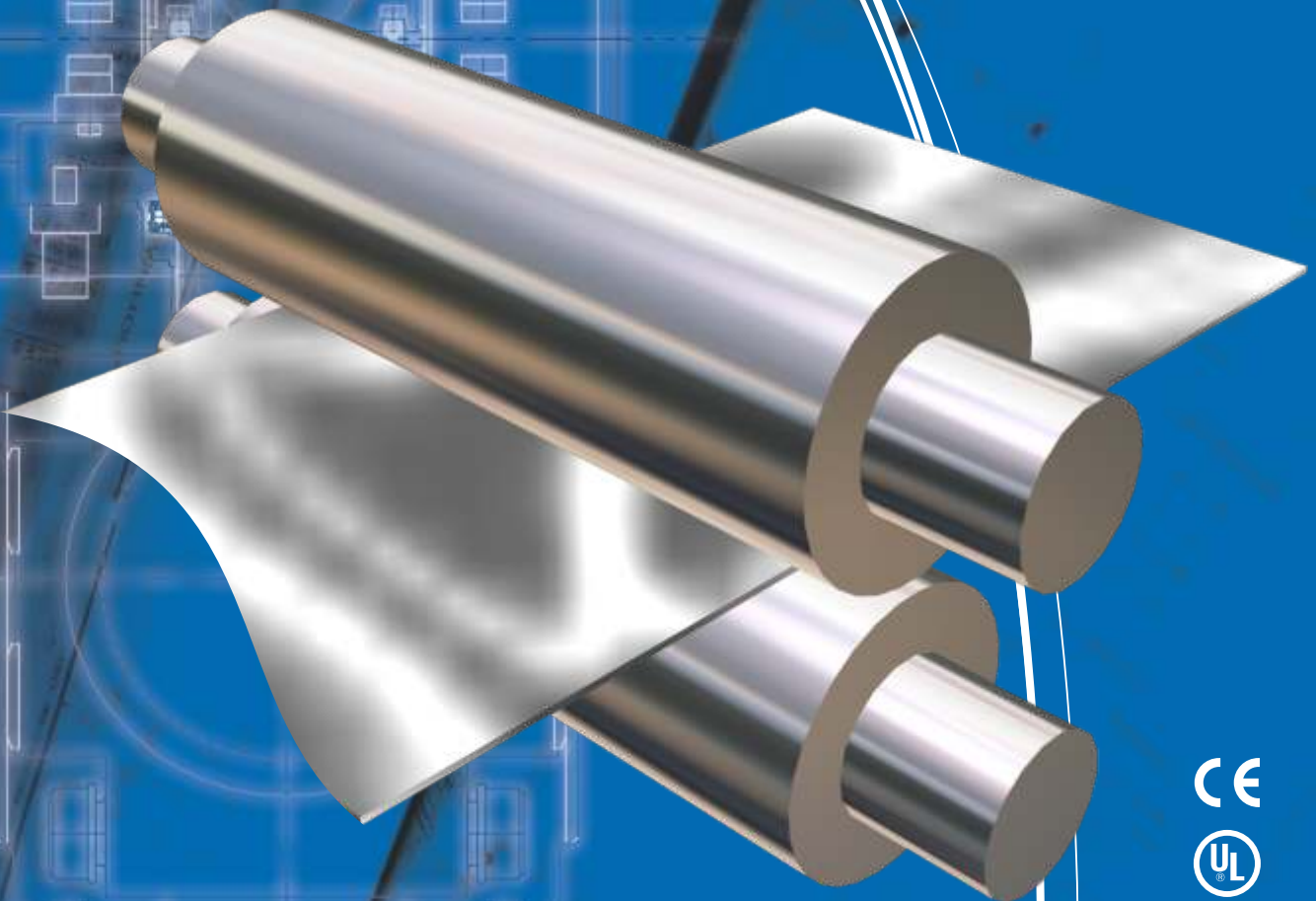
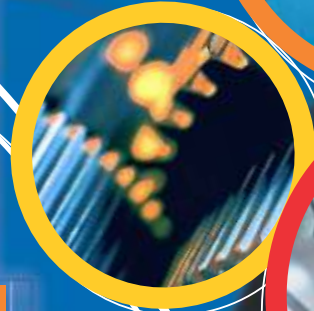

03

4 HI COLD ROLLING MILLS

05

6 HI COLD ROLLING MILLS

08

20 HI COLD ROLLING MILLS

10

GAUGE & SHAPE CONTROLS

11

TENSION REEL MANDRELS

MAGADH

Magadh has wide range of Cold rolling mills to suit varied application and requirements.

4 HI MILLS

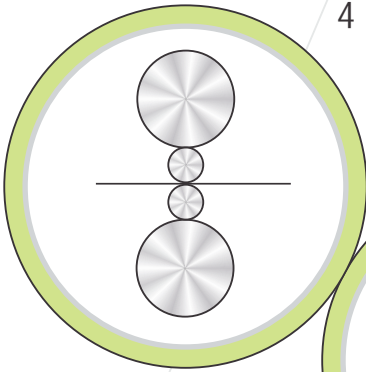

6 HI MILLS

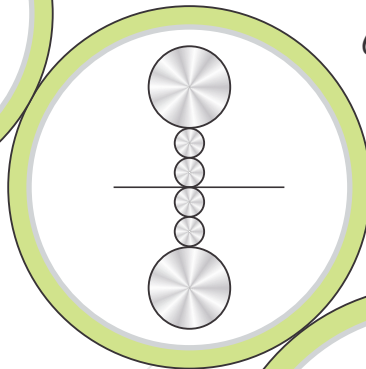

20 HI MILLS

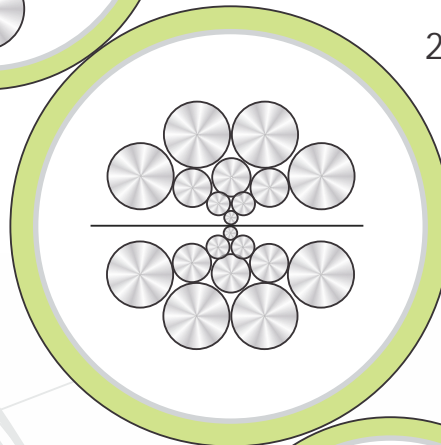

GAUGE & SHAPE CONTROL SYSTEMS

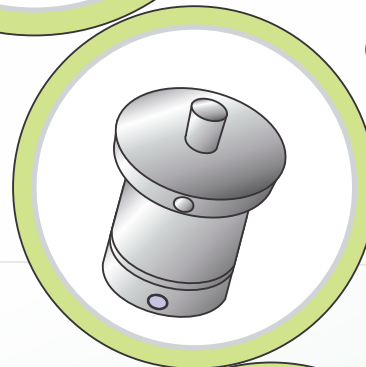

TENSION REEL MANDRELS

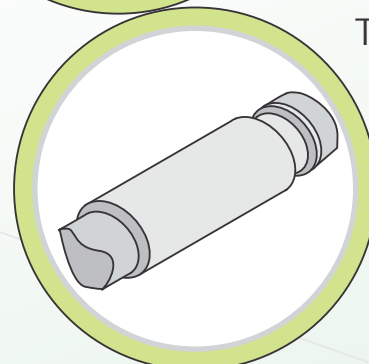

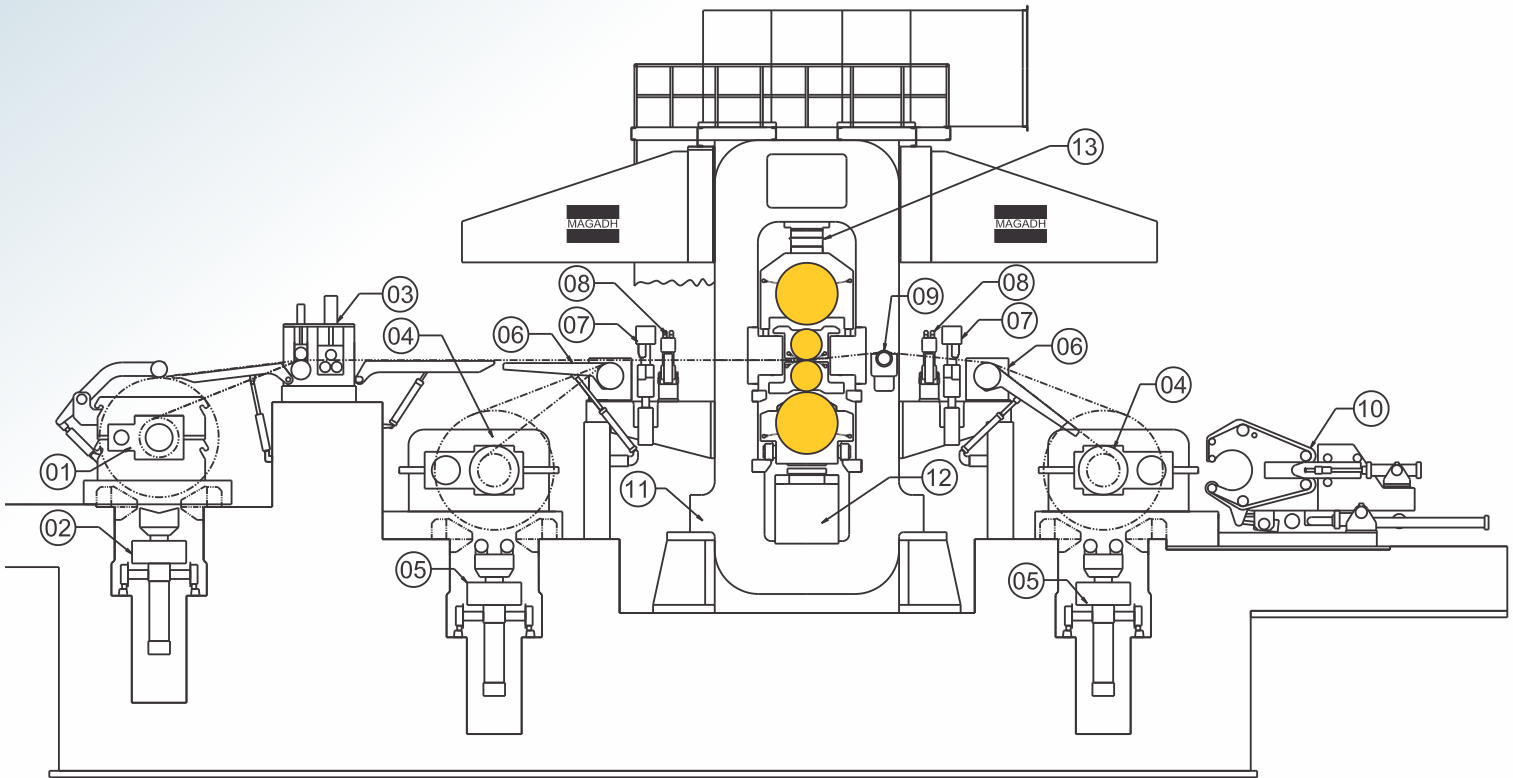

4 HI MILL ELEVATION

05	COIL CAR AT TENSION REEL	10	BELT WRAPPER		
04	TENSION REEL	09	TENSIO METER		
03	PINCH ROLL CUM FLATTENER	08	THICKNESS GAUGE	13	WEDGE BLOCK SYSTEM
02	COIL CAR AT PAY OFF REEL	07	SHEAR	12	HYDRAULIC AGC MECHANISM
01	PAY OFF REEL	06	DEFLECTOR ROLL WITH APRON	11	MILL STAND ASSEMBLY

## 4-HI REVERSING COLD MILLS

Magadh can offer 4 Hi reversing cold mills for strip width up to 1650 mm, minimum finish strip thickness up to 0.15 mm and mill speeds up to 1400 MPM.

The main mill features are :

- Balanced proportional design of Mill Stand.
- Quick response Hydraulic AGC System.
- High (+/-) work roll bending force per neck.
- Hydraulic BUR change system.
- Quick work roll change system with side shifter.
- Constant pass line with bottom beam mounted long stroke Roll force cylinder.
- Top mounted wedge gear system for top roll wear out compensation.
- Air-Oil /Oil Mist lubrication of roll neck bearings for high speed applications.
- Non contact Thickness Gauge.
- Shape control systems with zonal coolant control.

# 4 HI MILLS

04

## 4-HI TEMPER MILLS FOR PROCESS LINES

Recent trends in metal industry have resulted in increased use of Temper Mills as part of Processing Lines. Magadh can provide Temper Mills for Galvanizing Lines, Tension Leveling Lines, Pickling lines and Cut to Length lines in addition to Independent Temper Mills.

The heart of our temper mill offering high product quality is the Automatic Elongation System. With use of high resolution digital tachometers, computer control, and double acting roll force cylinders very high degree of elongation accuracy is provided. The elongation control system acquires elongation comparison signals by means of two high resolution tachometers located on entry and exit side. The elongation software calculates the actual elongation by comparing the measured "length in" and "length out" signals.

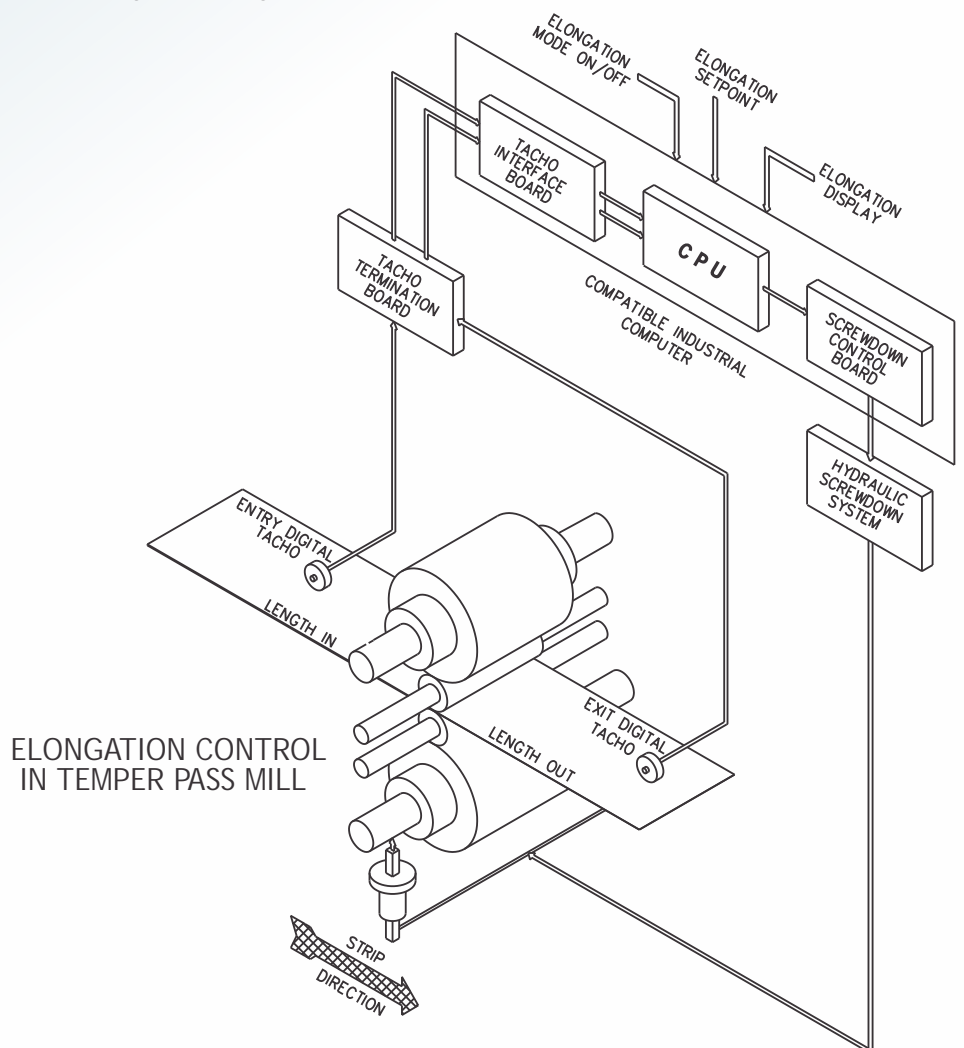

Magadh Temper Mills offer features like mae-west blocks for ease of roll removal, double acting roll bending cylinders, quick work roll change system with strip in mill, hydraulic wedge system for pass line adjustment, anti crimp rolls and cross bow rolls, on line polishers and roll bite lubrication systems.

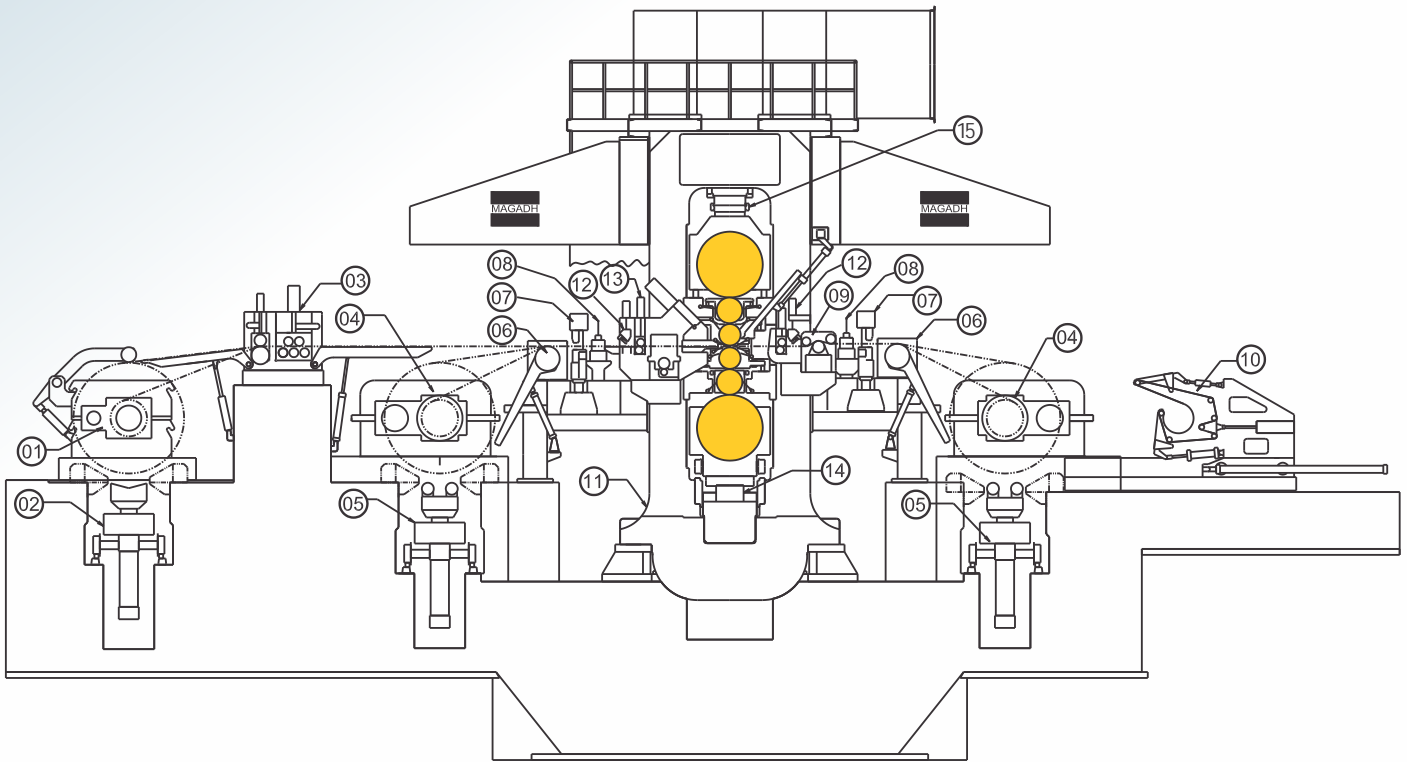

6 HI ELEVATION

05	COIL CAR AT TENSION REEL	10	BELT WRAPPER	15	WEDGE BLOCK SYSTEM
04	TENSION REEL	09	TENSIO METER	14	HYDRAULIC AGC MECHANISM
03	PINCH ROLL CUM FLATTENER	08	THICKNESS GAUGE	13	ROLL WIPER
02	COIL CAR AT PAY OFF REEL	07	SHEAR	12	AIR WIPER
01	PAY OFF REEL	06	DEFLECTOR ROLL WITH APRON	11	MILL STAND ASSEMBLY

## SIX-HI REVERSING COLD MILLS

Magadh can offer 6 Hi reversing cold mills in single stand or twin stand configuration for strip width up to 1650 mm, minimum finish strip thickness up to 0.12 mm and mill speeds up to 1400 MPM.

The main mill features are:

- Balanced proportional design of Mill Stand ensuring high mill modulus.
- High bending loads per neck for crown-in and crown-out of work rolls.
- Positive and negative bending of intermediate rolls.
- Quick response static/dynamic IMR shifting with position transducers.
- Bottom/ Top mounted Quick response roll force cylinder with internal axi-symmetric mounting of position transducer for direct roll gap measurement.
- Hydraulic wedge gear system for constant passline and roll wear compensation.
- Highly efficient strip wiping system consisting of air and roll type wipers.
- State of the art level 2 / level 3 automation and controls with Mill Management System.
- Shape control systems with zonal coolant control.
- Condition monitoring system for mill bearings.

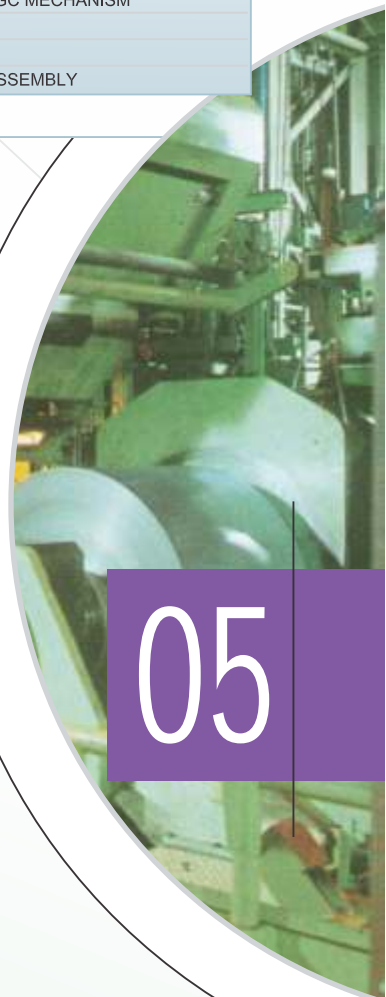

05

# 6 HI MILLS

06

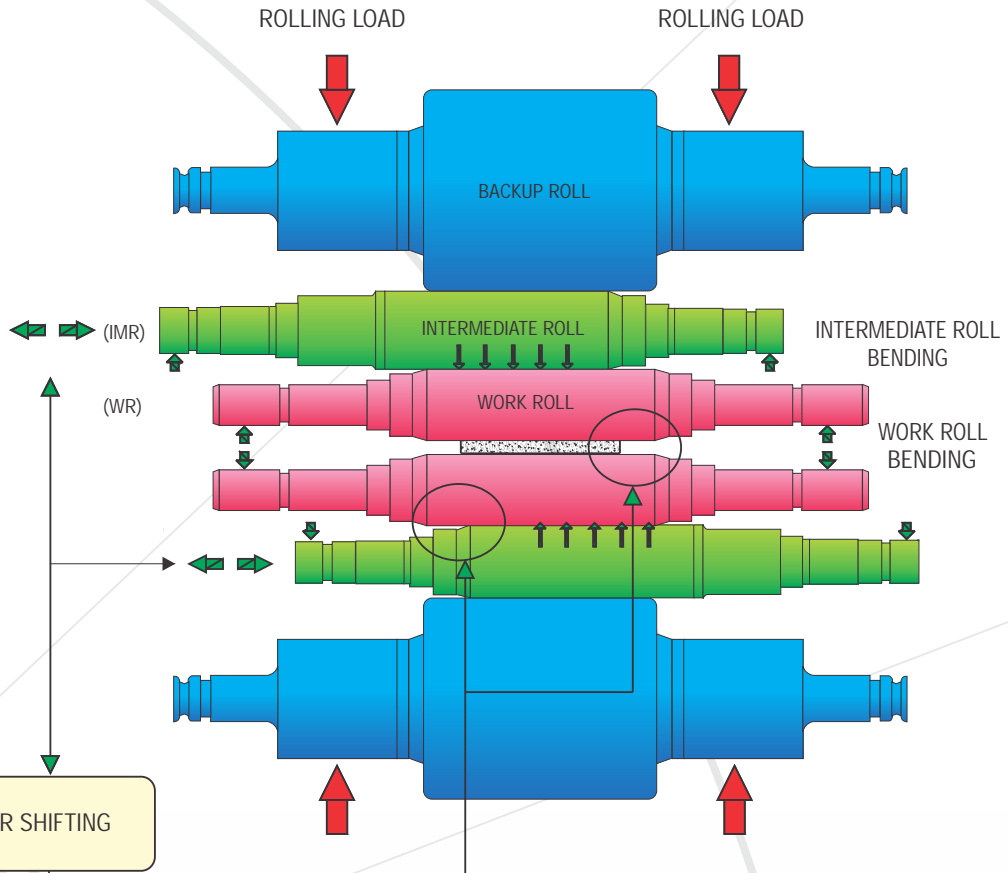
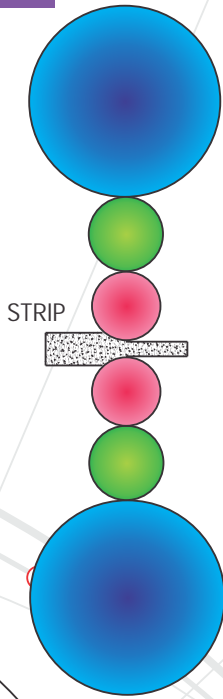

- ✓ CAMBERLESS WORK ROLLS CAN BE USED
- ✓ REDUCED WORK ROLL DIAMETER
- ✓ EFFECTIVE WORK ROLL BENDING
- ✓ REDUCED EDGE DROP
- ✓ REDUCED WORK ROLL DEFLECTION

PRINCIPLE OF 6-HI UC MILL

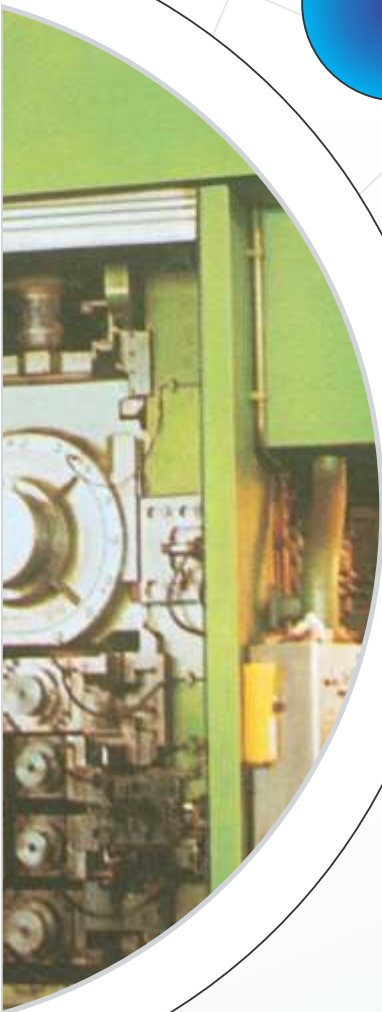

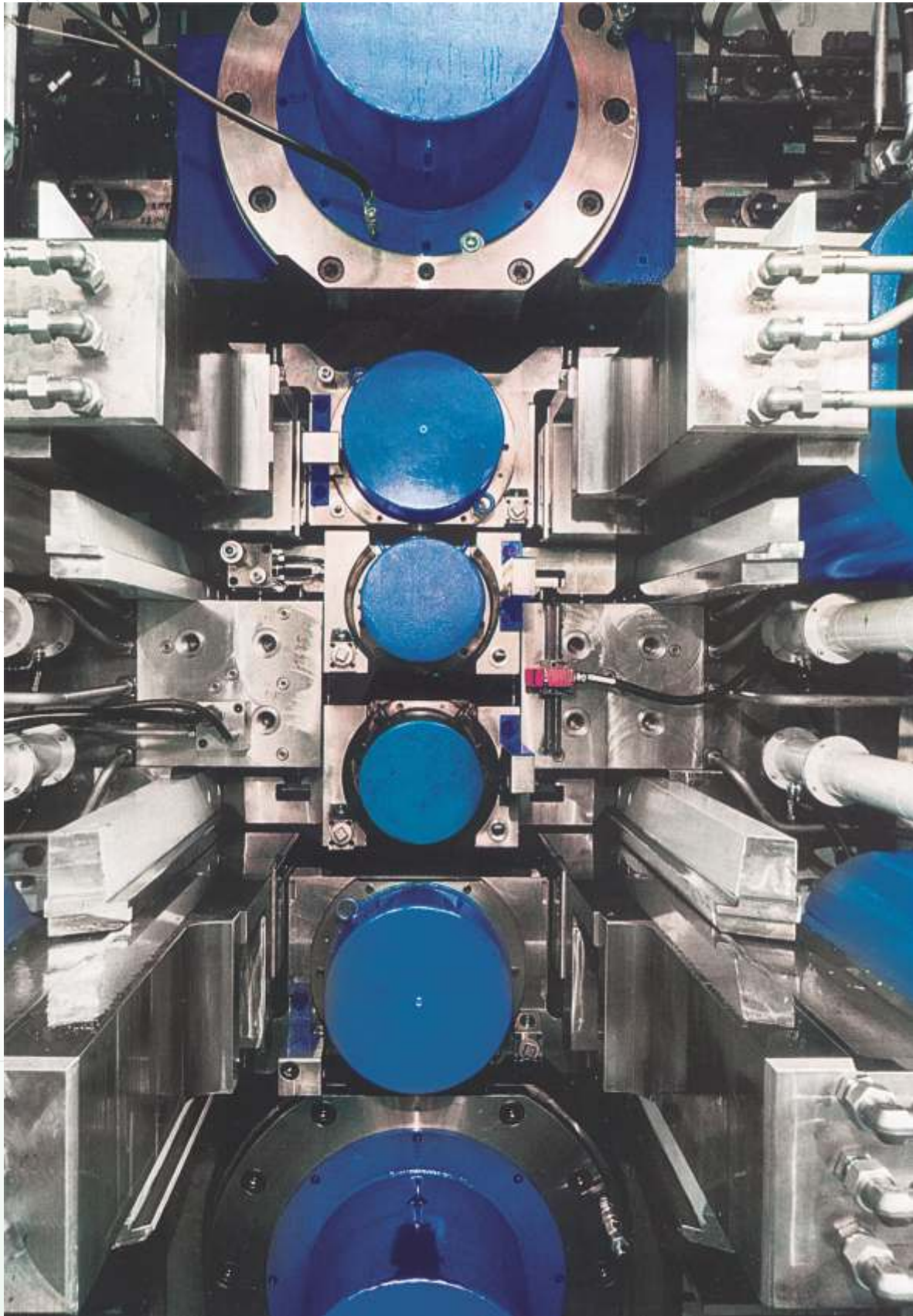

WINDOW ASSEMBLY OF SIX HI COLD MILL

# 20 HI MILLS

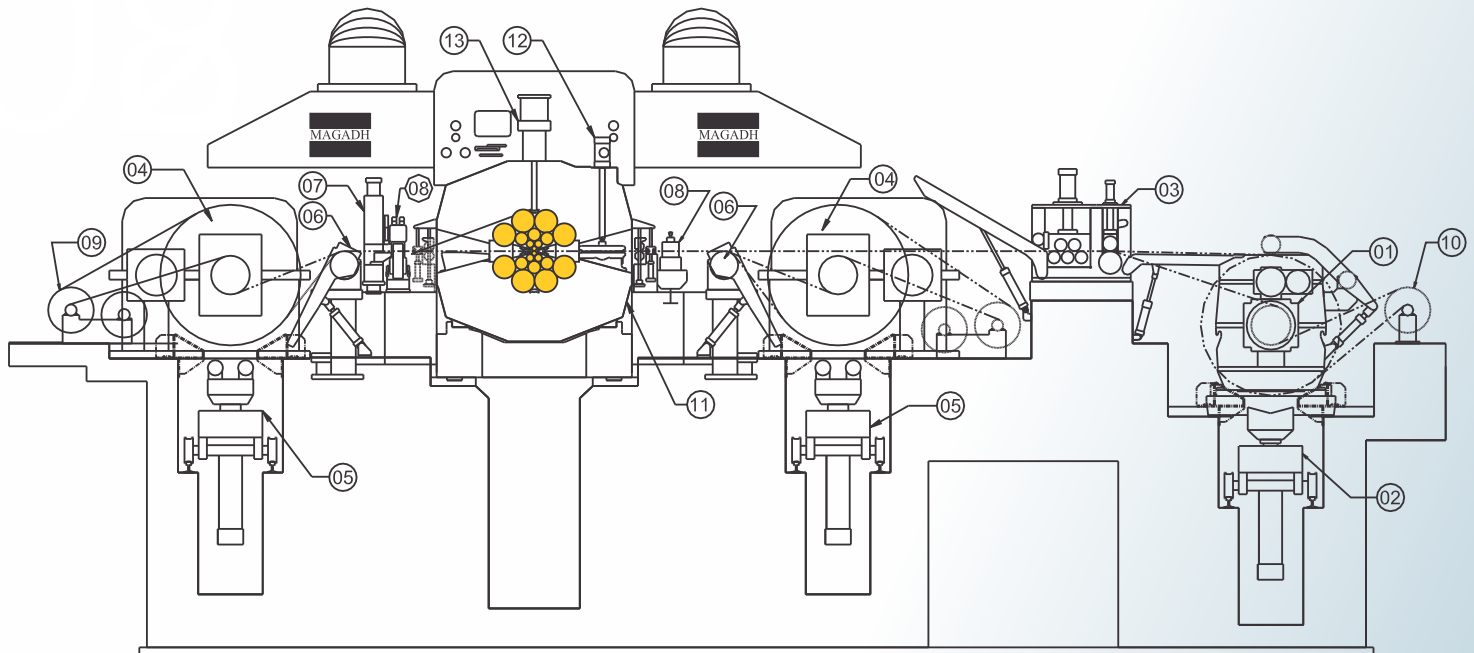

20 HI MILL ELEVATION

05	COIL CAR AT TENSION REEL	10	PAPER WINDER		
04	TENSION REEL	09	PAPER UNWINDER	13	HYDRAULIC AGC MECHANISM
03	PINCH ROLL CUM FLATTENER	08	THICKNESS GAUGE	12	PRESSURE PAD, SIDE GUIDE, ROLL WIPER & AIR WIPER
02	COIL CAR AT PAY OFF REEL	07	SHEAR		
01	PAY OFF REEL	06	DEFLECTOR ROLL WITH APRON	11	MILL STAND ASSEMBLY



## 20 HI COLD MILLS

Magadh can supply 20-hi mills for strip width up to 1625 mm, minimum finish strip thickness up to 0.05 mm and mill speeds up to 800 MPM which are quite popular for rolling high tensile ferrous and non-ferrous metal strips especially of wider width to thinner gauges more effectively than other mill designs.

20-hi mills are of mono block housing construction in which the roll separating force is transmitted from the work rolls, through the intermediate rolls to the multiple backup assemblies and finally to the housing (Figure 1). This ensures support of the work roll throughout their length thereby minimizing deflection which facilitates close gauge tolerance across the entire width of the strip.

20-hi mill is an economical solution for rolling of alloy steels and various grades of Stainless Steels in close gauge tolerance and minimum number of passes. The mill design is compact, screw down is hydraulic and crown control is hydraulic motor/cylinder actuated. Lateral adjustment is provided at first intermediate rolls while the mill drive is connected through second intermediate rolls. Roll changing is quite simple, foundation costs are reduced and smaller roll grinders are required for grinding of work and intermediate rolls.

08

- Monoblock Construction and robust mill housing for roll cluster ensuring high mill modulus and minimal transversal variation of mill modulus.
- Quick response hydraulic AGC of middle BUR'S with internally mounted position transducers and high precision servo valves.
- Servo hydraulic actuated AS-U Roll system for crown control (Figure 2).
- Hydraulically operated dynamic IMR shift system for shape control.
- Hydraulically assisted screw down system for constant passline.
- Precision machined and matched high quality mill fills and hardened and ground combination pinion stand elements ensuring smooth and continuous rolling operation.

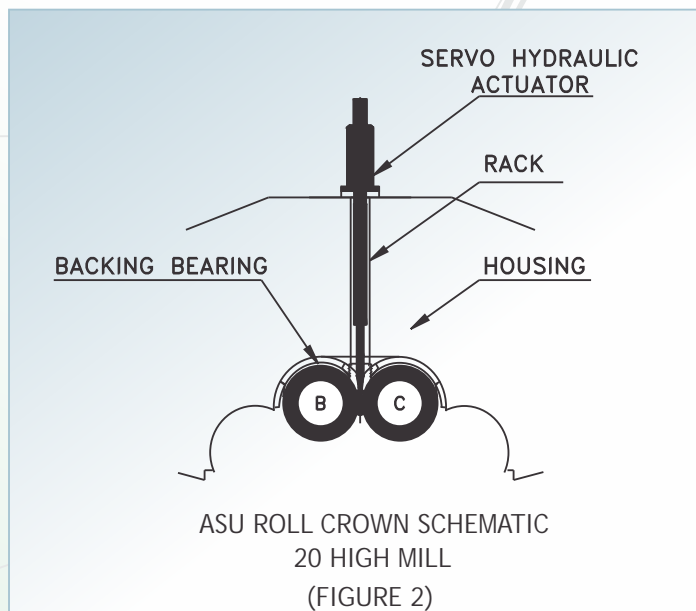
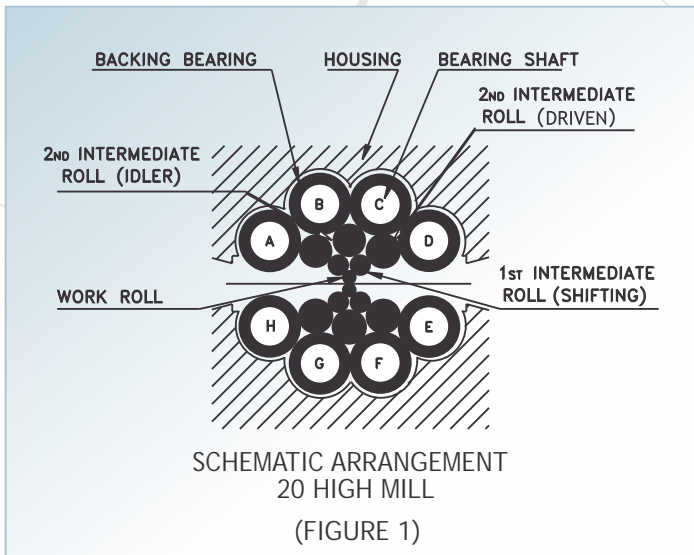

# GAUGE & SHAPE CONTROLS SYSTEMS

## HYDRAULIC AUTOMATIC GAUGE CONTROL

Magadh can supply computerized Hydraulic Automatic Gauge Control, (HAGC) System which provides quick and accurate screw down control to hold close strip tolerances necessary to meet the stringent demands of the market. The roll force cylinders are made from solid forged and heat treated alloy steel blocks precision machined and fitted with special hydraulic seals capable of continuous high pressure duty and quick response and are equipped with absolute position transducers of SONY Magnascale/equivalent make for precision position feedback.



## SHAPE CONTROL SYSTEM

Magadh can offer shape control system for automatic flatness control with aim to achieve uniform stress distribution in flatness tolerance range of rolled strip.

The flatness measuring roll is installed as measuring transducer on mill which registers all strip tension variations across the strip width and compares with the tension stress reference curve. The pressure transducers are arranged in staggered manner over the roll surface, connected in groups and fed to charge amplifier, which converts the electric charge into proportional voltages. The optical signals are transferred to acquisition CPU of flatness control computer via optical transmitter.

Elements of Flatness Control are:

- Shifting of Rolls
- Tilting of rolls
- Work Roll Bending
- Intermediate Roll Bending
- Roll Cooling (Zonal)
- Crown Control

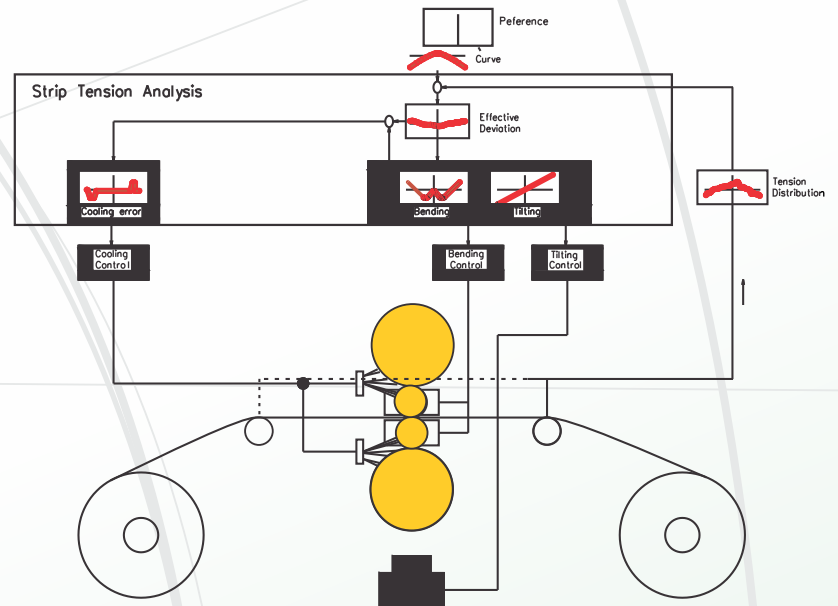

10

Advantages of Flatness Control are:

- Reduction in strip cracks and breakage
- Increase in mill efficiency
- Improvement in strip shape by uniform tensile stress over strip width
- Reduced dependency on mill operator's skill

During the process of cold rolling build-up of large coils of thin strip causes collapsing pressure. To meet these operational requirements, special collapsible reel mandrels have been designed with multiple pyramid sliding surfaces, integral with the mandrel shaft of alloy forged steel construction. The sliding surfaces are deposited with aluminum bronze material to minimize friction and facilitate maintenance free sliding surfaces. The segments are made of alloy steel, hardened and tempered, resulting in optimum strength, and long service life. The mandrel is provided with alloy steel gripper elements, hydraulically operated, ensuring effective grip during mandrel expansion. These tension reel mandrels are supported on rigid outboard bearing supports during rolling.

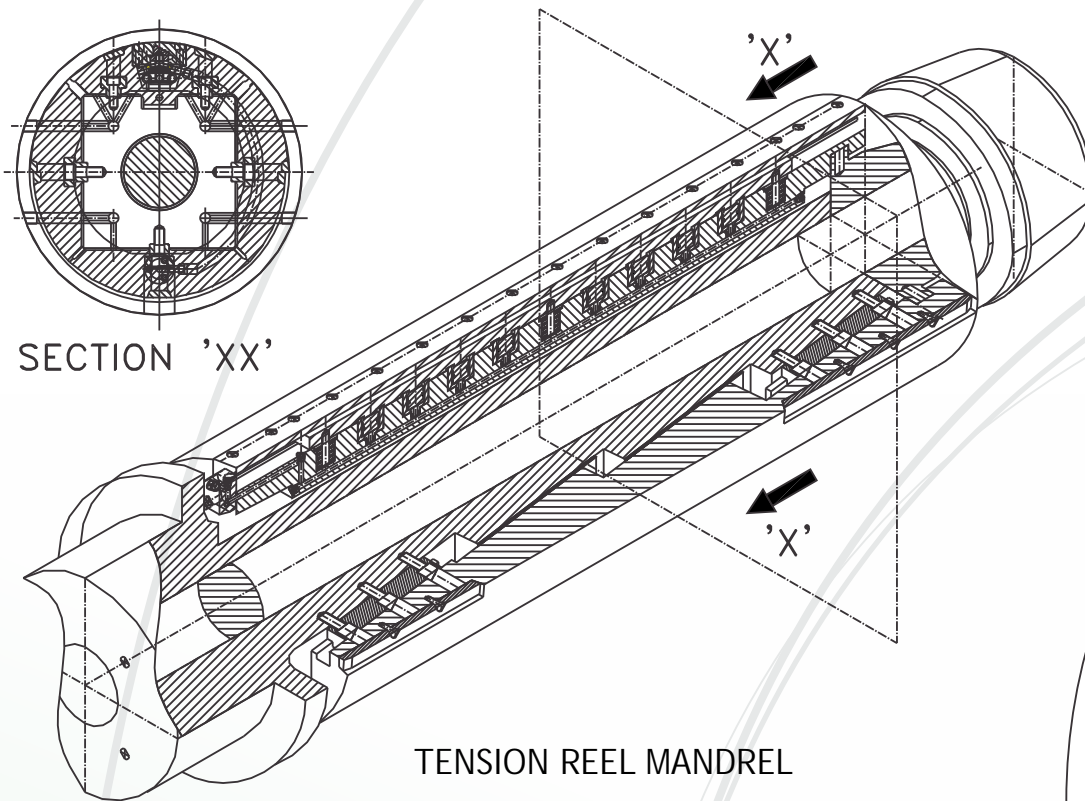

Magadh can also supply heavy duty Inverse Pyramid Mandrels. Cold Rolling of alloy steels like stainless steel demands extremely high winding tension and for such applications inverse pyramid tension reel mandrels are ideally suited. The multiple pyramid mandrel is made from a solid forged alloy steel shaft having higher section modulus which also acts like a pull rod. The mandrel shaft is axially actuated by means of a hydraulic cylinder which causes drum expansion/collapse. The segments are axially held by the gear shaft adopter, which permit radial movement of the segments when pushed by the wedge action of the pyramid.



Scan to Visit Our Website



## MAGADH PRECISION EQUIPMENT LIMITED

(A Government of India Recognized Star Export House)



### Sales Office:

D-26, D.S.I.D.C. Complex,  
Kirti Nagar, NEW DELHI 110 015, INDIA  
Phones : 25925635, 25925442  
Fax : +91 11 41420442

### Head Office & Works:

11, Industrial Area # 2, A B Road, DEWAS 455 001, M.P., INDIA  
Phones : +91 7272 426300 (Hunting), 259400 to 259403  
Fax : +91 7272 258958, 258523  
e-mail : admin@magadh.in, parijat@magadh.in

Follow Us on -  

[www.magadh.in](http://www.magadh.in)